





 **Genie Race<sup>5</sup> COMPETITION HARNESS**

Whilst Gin Gliders has made every effort at the time of publication to provide accurate information, product specifications are subject to change without notice and may vary from those shown.

# CONTENTS

Genie Race<sup>5</sup>

Thank You .....	4	Storage .....	27
Warning .....	5	Adjustments .....	28
Introducing Genie Race <sup>5</sup> .....	6	Guide to putting on the harness .....	32
Specifications .....	7	Attaching the flight deck .....	33
Components of The Genie Race <sup>5</sup> .....	8	Flying with the Genie Race <sup>5</sup> .....	39
Before You Fly .....	11	Maintenance and Repairs .....	42
Speedbar installation .....	12	Final Words .....	45
Seatplate installation .....	13	Harness Diagram .....	49
Back protector installation .....	14		
Maintening the back protector .....	15		
Support pillars installation .....	16		
Ballast container installation .....	17		
Rescue Installation .....	18		
Footpad installation .....	23		

# THANK YOU

**For choosing Gin Gliders. We are confident you'll enjoy many rewarding experiences in the air with your new GIN harness.**

This manual contains important safety, performance and maintenance information. Read it before your first flight, keep it for reference, and please pass it on to the new owner if you ever re-sell your harness.

Any updates to this manual, or relevant safety information, will be published on our website: [www.gingliders.com](http://www.gingliders.com). You can also register for e-mail updates via our website.

Happy flying and safe landings,  
GIN Team



## **WARNING**

Like any extreme sport, paragliding involves unpredictable risks which may lead to injury or death. By choosing to fly, you assume the sole responsibility for those risks. You can minimize the risks by having the appropriate attitude, training and experience and by properly understanding, using and maintaining your equipment. Always seek to expand your knowledge and to develop self-reliance. If there is anything you do not understand, consult with your local dealer as a first point of contact, with the GIN importer in your country or with Gin Gliders directly.

Because it is impossible to anticipate every situation or condition that can occur while paragliding, this manual makes no representation about the safe use of the paragliding equipment under all conditions. Neither Gin Gliders nor the seller of GIN equipment can guarantee, or be held responsible for, the safety of yourself or anyone else.

Many countries have specific regulations or laws regarding paragliding activity. It's your responsibility to know and observe the regulations of the region where you fly.

**INTENDED USE:** *Lightweight air sports equipment with a maximum mass of less than 120kg, operated in the paragliding division.*

# INTRODUCING THE GENIE RACE<sup>5</sup>

The Genie Race 5 is designed to offer the highest levels of performance, whilst giving you an edge through its superior comfort and ergonomics.

The goal with the Genie Race 5 was to reach the top level of performance of a fully enclosed harness whilst making the harness easier to use in flight. By using a fabric with more structure, and introducing plastic reinforcements in strategic places, we were able to keep an external profile that's beneficial for performance as a result of its simple, clean shape and resistance to fluttering and flapping.

Pilot ergonomics are an important factor in comfort and ultimately, performance. So we made everything as easy to use as possible: the cockpit, the system of opening and closing, the trimming. As a result, besides competitors, the harness is also great for the most competitive XC pilots.

## PROVEN AERODYNAMICS

Genie Race 5 It is the result of a period of intensive development in the GIN LAB wind tunnel and of racing the prototypes worldwide.



# SPECIFICATIONS

Size	XS	S	M	L	XL
Pilot height (cm)	>165	160-175	170-180	180-190	190-200
Rescue volume (L)	9.8	9.8	9.8	11	11
Carabiner distance (cm)	44	45	45	47	47
Seat plate width (cm)	31	32	33	35	35
Seat plate length (cm)	43	44	45	47	47
Ballast container volume (L)	10	10	10	10.5	10.5
Under seat pocket volume (L)	3.8	3.8	3.8	3.8	3.8
Rescue bridle length (mm)	1220	1220	1220	1220	1220

\* Delivered with 2 inner containers and 2 rescue bridles

\* Delivered with 3 foot pads: 2.5cm / 5cm / 7.5cm

## CERTIFICATION

The Genie Race<sup>5</sup> is **EN** and **LTF** certified, max load 120 daN

Certification number: **PH 387.2023** | **CE** certification

## DELIVERY PACKAGE

- 1 Harness
- 1 Triplex seat plate
- 1 Flight deck (removable), with additional 1L pocket
- 1 Hook knife
- 2 Rescue inner bag
- 2 Rescue deployment handles
- 2 Rescue bridles
- 2 GIN 30mm carabiners
- 1 Ballast container (10L)
- 3 Footpad (2,5, 5, 7,5 cm)
- 1 Underseat pocket. 3.8L

## BACK PROTECTION

KOROYD 1.0

9cm back protection

CE and EN Certified

## HARNESS COMPONENT WEIGHTS

COMPONENTS	XS	S	M	L	XL
Rescue handle 2 sets (kg)	0.052	0.052	0.052	0.052	0.052
Rescue inner bag 2 sets (kg)	0.052	0.052	0.052	0.052	0.052
Rescue bridle 2 sets (kg)	0.092	0.092	0.092	0.092	0.092
Speed bar (kg)	0.08	0.08	0.08	0.08	0.08
Koroyd 1.0 (kg)	0.377	0.377	0.377	0.377	0.377
Cockpit plate (kg)	0.246	0.246	0.246	0.246	0.246
Ballast container (kg)	0.254	0.254	0.254	0.26	0.26
Harness without carabiner (kg)	5.5	6.2	6.347	6.8	7.2
Harness weight (kg)	6.653	7.353	7.5	7.959	8.3

# COMPONENTS OF THE GENIE RACE<sup>5</sup>

## 1 BACK PROTECTION

The Genie Race<sup>5</sup> comes with the Neo Koroyd back protector. The protection must be inspected after any impact and assessed for damage. A damaged back protector must be replaced before the next use. The protector protects the pilot as much as possible in the event of an incident, but it cannot completely eliminate the risk of injury. The Genie Race<sup>5</sup> back protection is EN and CE certified.

<https://koroyd.com/>

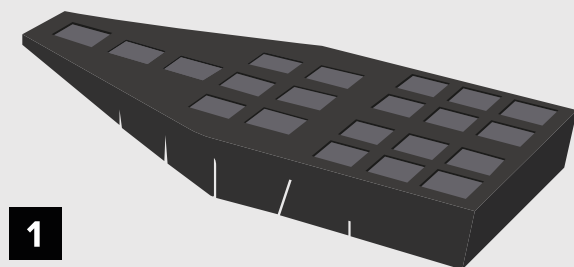

## 2 TRIPLEX SEAT PLATE

Included with your harness is a triplex seat plate and a triplex foot plate. Both are durable and strong while providing you with a much lighter and durable alternative to wood.

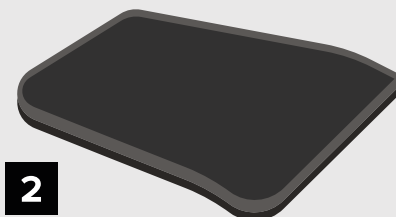

## 3 GIN CARABINERS

Included with your harness is a pair of GIN 30mm carabiners. The Genie Race<sup>5</sup> is not compatible with quick release carabiners. Automatic aluminium carabiners have a limited lifetime due to metal fatigue. They must be replaced after 5 years or 500 flight hours, whichever is soonest. They should never be used between spreaders and tandem wing risers as main carabiners. They should also never be used to connect bridles to the reserve.



## 4 FLIGHT DECK

Included with the Genie Race<sup>5</sup> harness is a custom designed flight deck, with integrated hook knife. The flight deck is designed to seamlessly connect with the cocoon, providing you with room for a GPS and vario or other flying instruments. The flight deck also has a 'L pocket to be used for storing easy access items in flight and with cable routing to store a power bank etc.

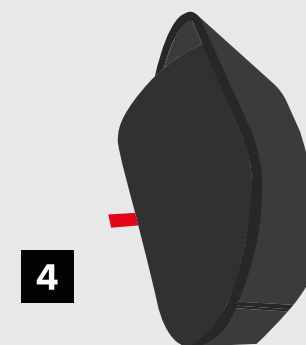

## 5 BALLAST CONTAINER

The Genie Race<sup>5</sup> comes with a ballast container of 9L capacity. There is a frontal zipper on the top part to provide easy fitting of the water ballast, and 6 attachment straps to offer the best hanging position and comfort in flight. Top straps are attached to the shoulder straps to help support the ballast while on the ground. The harness may be flown with or without the ballast container. Please, read page 17 for the ballast container installation.

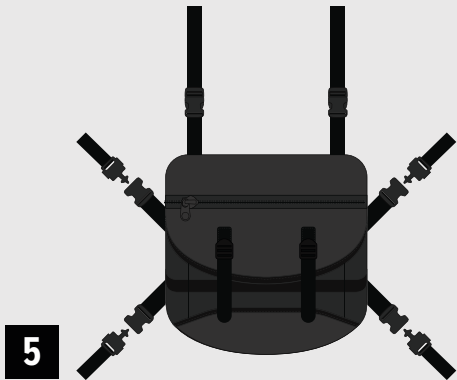

## 6 FOOTPAD

In order to adjust the inner structure to the outershell of the harness, pilots must adjust the base length with a footpad. We're supplying 3 different lengths: 2.5, 5, and 7,5cm footpads to match the length of the pilot with the outershell. Please, read page 23 for the footplate installation.

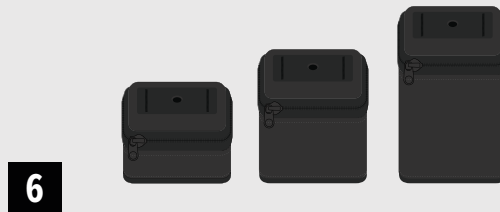

## 7 SPEEDBAR

Included with your harness is an asymmetric speedbar. This enables the pilot to use it with only one leg for each step and thus maintain the speedbar pulleys in a symmetrical position at all times. Please, read page 11 for the speedbar installation.

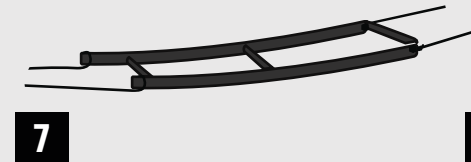

## 8 HOOK KNIFE

Integrated on the flight deck there is a hook knife, with a security line to avoid losing it during flight. The hook knife is a safety feature that allows the pilot to cut the risers or lines in case of an accidental water landing or if the pilot is being dragged, for example by a deployed rescue.



## 9 RESCUE DEPLOYMENT HANDLES (2)

The Genie Race<sup>5</sup> comes with 2 rescue deployment handles. One for the right side and another one for the left side. The rescue deployment handle comes with 2 parachord plastic rods to close the outershell layer and the inner container located in the harness. Check the parachord loops before every take off and make sure the rescue container is closed before taking off.

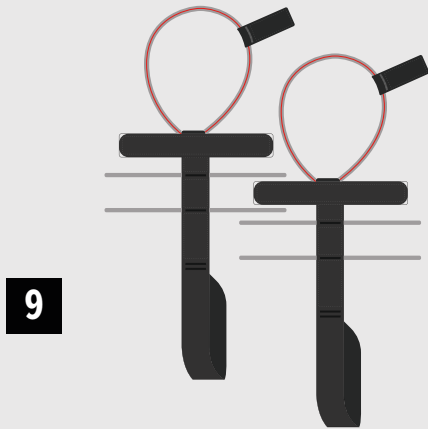

## 10 RESCUE INNER BAGS (2)

Included with your harness there are two rescue inner bags. You need to install your rescues inside the supplied inner bag in order to guarantee the correct extraction of the rescue.  
Make sure you install the rescue following the correct procedure, shown on page 18

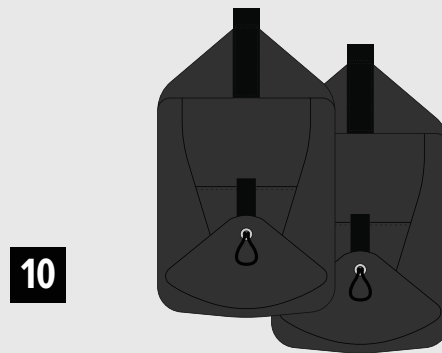

## 11 RESCUE BRIDLES (2)

Included with your harness is a pair of 300 mm rescue bridles. They are supplied already attached to the harness, please attach them to your rescue riser following the instructions shown on page 21

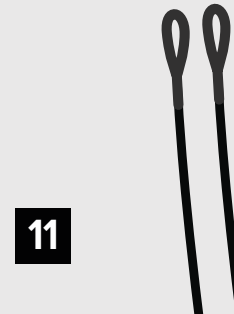

# BEFORE YOU FLY

Make sure your dealer has checked the harness for completeness and basic settings. Your harness must be assembled by a suitably qualified paragliding professional, for example, your instructor.

Gin Gliders recommends that assembly be carried out in the following order. If you are in any doubt whatsoever about this procedure, please seek professional advice from your instructor, GIN dealer or importer.

## INSTALLING THE SPEED SYSTEM

Assemble the speed system from bottom to top. Attach the elastic cord of the speedbar to the foot plate of the cocoon (1). Connect the cord to the speedbar using a secure knot (2). From the speedbar, route the cord through the small pulley at the bottom of the seat (3). Pass the cord along the inside of the harness and route it through the metal eyelet (4). Connect the chord to the glider riser (5) see page 12 for the riser connection.

Hanging in the simulator, adjust the length of the speed bar cord so that the bar hangs at least 15cm below the front of the harness. Making the cord too short could result in the speed system being constantly or unintentionally engaged during flight. It is safer to start with the speed bar a little long and shorten it following your first flights. Test the speed bar in flight only after you are comfortable with your new harness, and always do so in calm conditions with enough clearance above the ground.

\* See page 22 for speed system adjustment

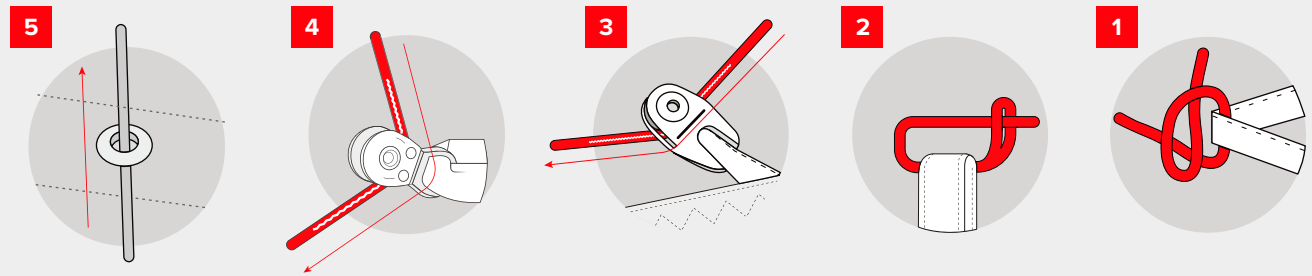
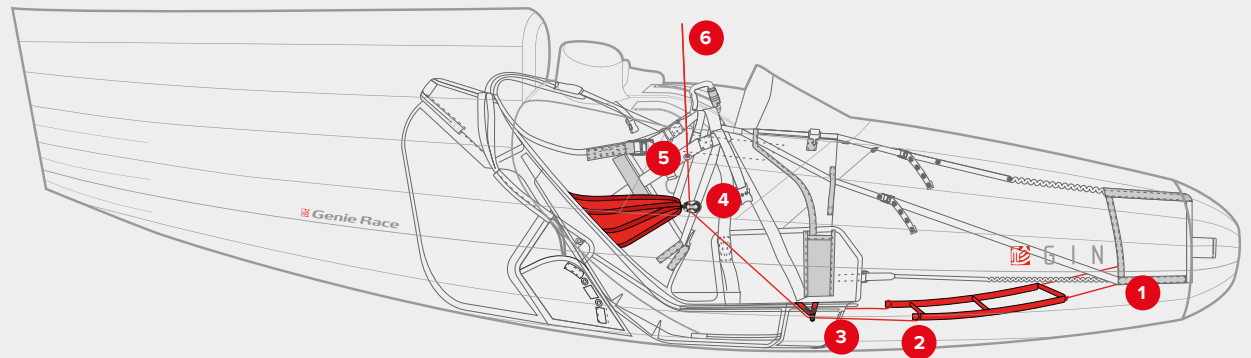

**! CAUTION:** Make sure that the speed system is not too short. The front risers of your paraglider must not be pulled down in normal (unaccelerated) flight.

## INSTALLING THE SPEEDBAR ON THE GLIDER RISER

In order to improve the aerodynamics of the harness, the Genie Race 5 comes with an integrated speedbar line, which is connected from the harness directly to the glider riser. Please install it following the steps below.



1 Once the riser speed line has been removed, pass the speedbar line through the top pulley



2 After passing it through the top pulley, pass the line through the bottom pulley

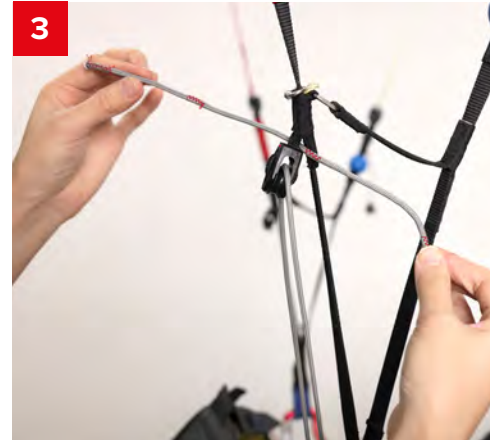

3 Pass the line through the top webbing of the top pulley

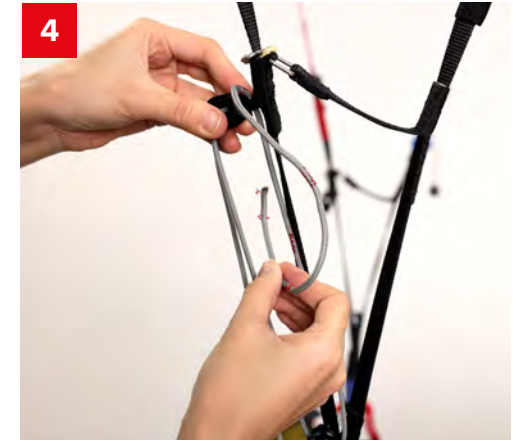

4 Make a loop around the pulley webbing

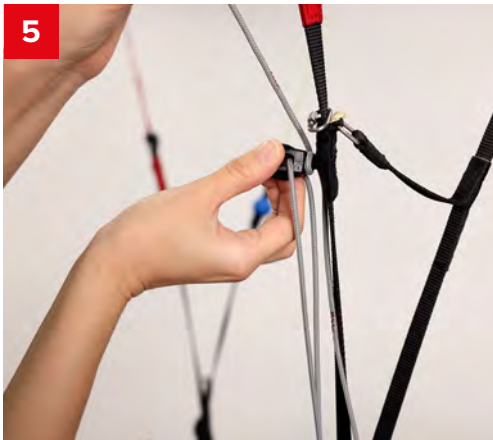

5 Tighten the loop to keep the speedbar line in position

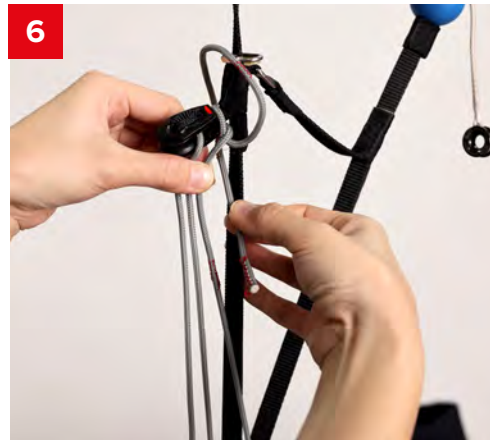

6 Make a second loop over

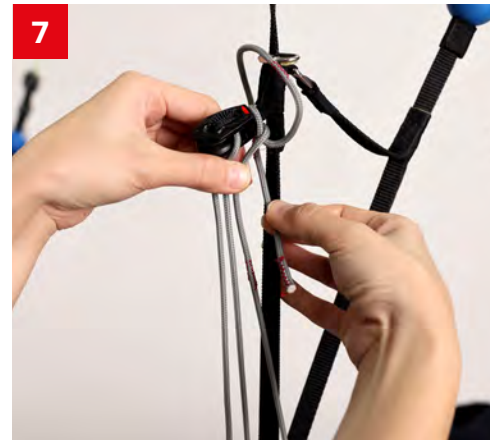

7 Pass the line inside the second loop

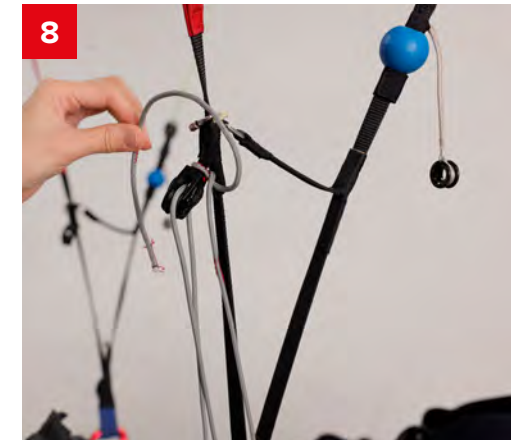

8 Tighten the knot on the second loop and make sure the line is securely fixed

## INSTALLING THE SEAT PLATE

The seat plate is removable and can be accessed by a panel at the back edge of the seat. The seat plate should be installed with the round corners orientated to the rear of the harness and the square corners at the front. After installation be sure to close the velcro flap properly.

**WARNING:** Forgetting to loop the leg straps behind the seat plate may place the pilot at risk of falling out of the harness.

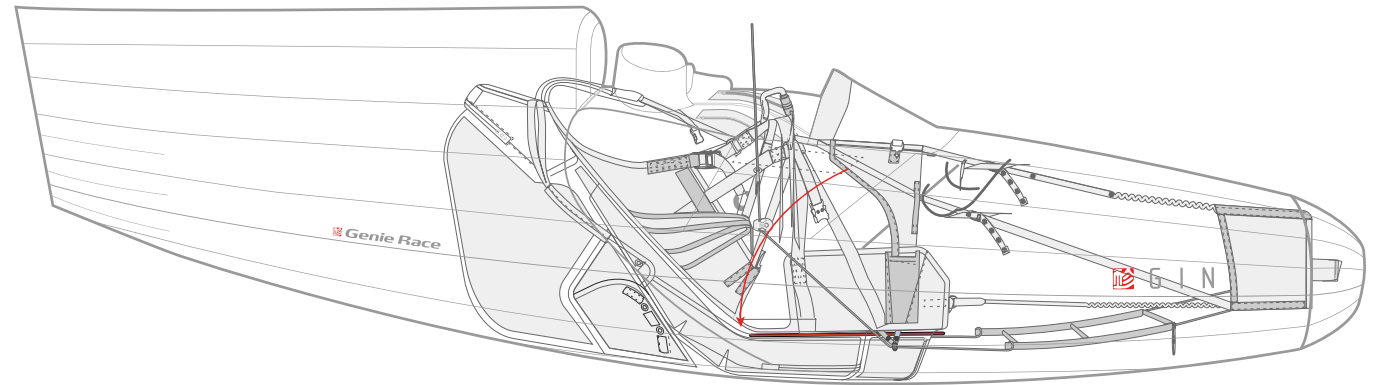

## INSTALLING THE BACK PROTECTOR

To install the back protector in the Genie Race<sup>5</sup>, first open the zipper compartment under the seat. Insert the back protector narrow end first. Guide the back protector into the correct position making sure that the narrow top piece properly sits between the back support and the rescue container. The back protector should fit snugly into the container. Once you are sure the protector is installed correctly, close the protector compartment zipper.

**! WARNING:** *The back protection does not eliminate the chance of injury as a result of a crash.*

**! WARNING:** *If the back protection zip is not fully closed, the protector will not work effectively*

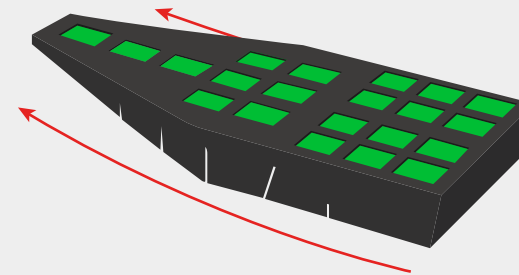
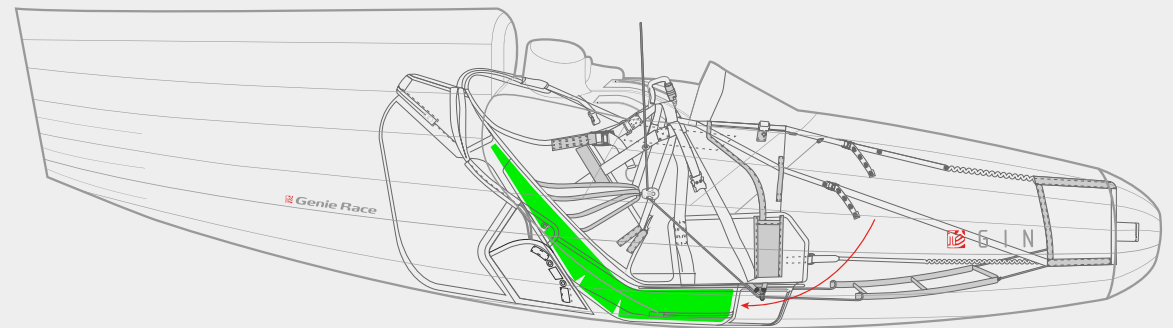

## MAINTAINING THE BACK PROTECTOR

We recommend that you inspect your back protection periodically in case it was damaged by rough handling at the take-off/landing or transportation (e.g. airport handlers).

We recommend that you do not fly with a back protector that shows signs of damage.

If one of the Koroyd blocks becomes damaged, they can be exchanged individually. Contact your local dealer to obtain a replacement.

**⚠ WARNING:** *If the harness is subjected to temperatures exceeding 70 degrees Celsius the integrity of the back protection may be compromised.*

**⚠ WARNING:** *The Koroyd 1.0 back protection has a valid lifetime of 5 years. The lifetime is a guide and may change depending on use, care and maintenance.*



Undamaged cell  
(No need to be replaced)



Damaged cell  
(Needs to be replaced)



NEO KORoyD 1.0

## SUPPORT PILLARS INSTALLATION

The support pillars are designed to hold the weight of the ballast and offer the pilot full comfort even while carrying a full ballast container. In flight, the weight of the ballast will rest on the base structure through the support pillars.

When packing and storing the harness in the rucksack, we recommend removing the support pillars after landing and installing them again prior to take off.

We always recommend flying with the support pillars installed even if not using the ballast container.

For the right installation of the support pillars, please follow the guide displayed here:

**! WARNING:** *If the harness is stored and compressed in the rucksack with the support pillars installed, it might damage the basement of the harness.*

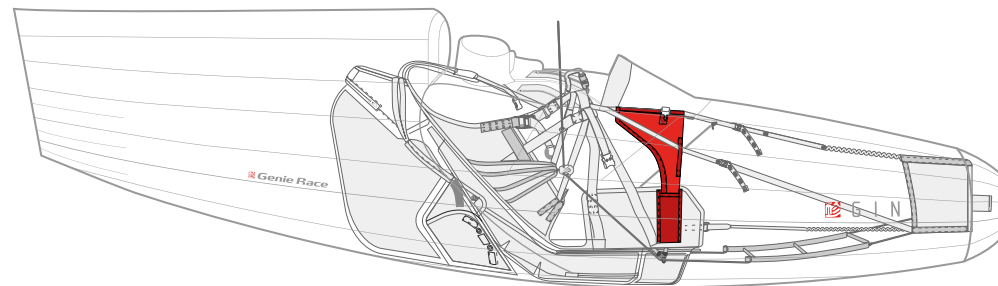

1 Make sure the support pillars are not wrapped or locked by any webbing or lines



2 Make sure the support pillar is inserted in the right pocket, otherwise the fabric could be damaged



3 Insert the support pillar in the right pocket



4 Pull the support pillar until the end of the pocket, and check it's fitted in the right position

## BALLAST CONTAINER INSTALLATION

On the Genie Race<sup>5</sup> there is a dedicated ballast container with a capacity of 10 L (M size). We recommend using it for water ballast. The Genie Race<sup>5</sup> may be flown with or without the water ballast container. The ballast container has 6 attachment points to the harness:

### 2 plastic buckles connected to the shoulder straps.

These help the pilot to hold the weight of the ballast on the ground.

### 2 metal buckles on the rear part of the support pillars

These hold the weight of the ballast during flight

### 2 metal buckles on the front part of the support pillars

These stabilize and distribute the load along the length of the support pillars.

Should you wish to remove some water from the ballast compartment in flight, open the vest zipper and take out the water by that route.

There are 2 compression straps in order to adjust the volume of the container to the volume of the ballast.

The ballast container should be installed before closing the outershell zipper.

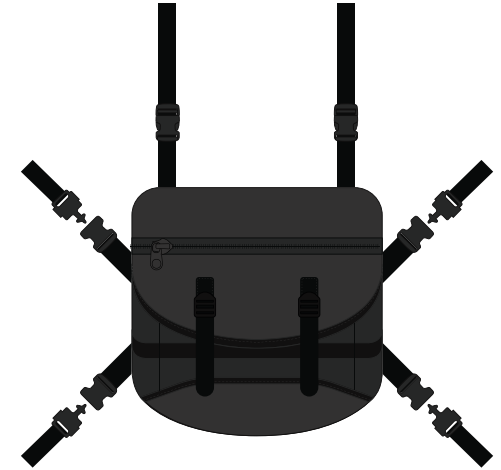

1 Attach the shoulder strap with the orange plastic buckle



2 Connect the rear support pillar metal buckle



3 Connect the front support pillar metal buckle and adjust the volume of the container with the red straps



4 Make sure the zipper is closed before closing the outershell of the harness

# RESCUE INSTALLATION

## RESCUE INSTALLATION AND COMPATIBILITY CHECK

Gin Gliders recommend that rescue installation is performed properly by a competent person. The rescue parachute is a pilot's last resort and failure to pack or connect the reserve parachute in the correct way may cause death or severe injury. The pilot is responsible for ensuring proper installation.

This harness is compatible with the Yeti UL, G-Lite (please check rescue size and volume), Yeti and Yeti Cross 2 rescue parachutes. Other manufacturers' rescues may also be used but we cannot guarantee their function. The pilot is responsible for checking compatibility.

Every first installation of a rescue system into the harness (that means every new combination of harness and rescue system) must be checked by a qualified paragliding professional for compatibility. To verify the installation, you must perform a test deployment by sitting in a simulator.

Rescue parachutes should be repacked at least every 150 days; so installing your rescue in a new harness may also provide a good opportunity for a repack. After every repack of the rescue parachute you should also do a compatibility check.

The harness is delivered with its own rescue deployment bag. This bag **MUST** be used when installing the rescue. The use of other rescue deployment bags may cause deployment failure.

## RESCUE COMPATIBILITY

**MAKE SURE THAT THE RESCUE PARACHUTE CAN BE RELEASED FROM THE RESCUE CONTAINER**—*it must be done by you, the pilot, sitting in the harness hanging from a simulator.*

## RESCUE DEPLOYMENT

To deploy the rescue; locate the handle, with a firm grip pull the handle towards the pilot and slightly away from the harness to extract the rescue from the harness compartment. In the same motion that pulls the rescue from the compartment swing the rescue by the handle while looking for clear airspace (clear of lines, glider and harness). Release your grip of the handle and allow both handle and rescue to travel through the air extending the rescue lines as it goes. The rescue should come out of the deployment bag and start to inflate once the rescue lines have been extended.

In a negative spin the decent speed of the the pilot and wing is much less than in a spiral situation. Therefore it is very important to throw the rescue away from the pilot with as much power as possible to quickly extend the lines and prevent the rescue from becoming entangled with the paraglider.

For further information on rescue deployment please refer to your rescue manual.



## VIDEO MANUAL

- You also can check the video manual for the rescue installation of the Genie Race 5
  - <https://www.youtube.com/watch?v=cOgy1izpScw>



**! WARNING:** *If you are in any doubt about any aspect of rescue installation, seek professional advice!*

**I IMPORTANT:** *You must perform a test deployment from a simulator to verify the installation.*

## ATTACHING THE RESCUE DEPLOYMENT BAG TO THE HARNESS DEPLOYMENT HANDLE

The rescue container for this harness comes with its own deployment handle, which **MUST** be used. This handle and its strap must be connected to the deployment bag of the parachute. In particular, check the length of the strap connecting the rescue deployment handle to the rescue inner container. It should be long enough that the reserve can be extracted without the danger of the pin not being pulled before the strap tightens on the reserve, but not so long that there is excessive slack that extends the movement required for deployment.



## INNER BAG



1 Handle attachment



2 Pass the handle through the center loop

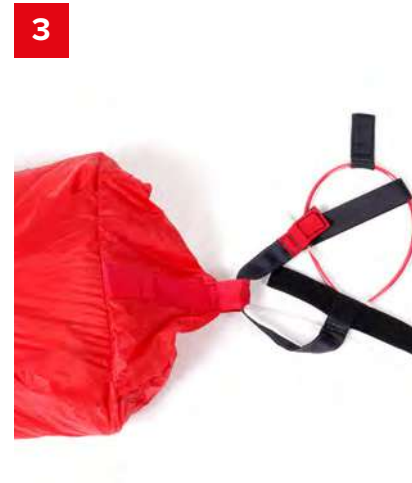

3 Pass the handle through itself



4 Pull to make a clean, tight knot

**IMPORTANT:** Use only the rescue deployment bag supplied with your Genie Race 5. The use of other rescue deployment bags may cause deployment failure.

## INNER CONTAINER PACKING

Your rescue should be repacked into the supplied inner containers as follows.



**1**  
Place the folded rescue into the inner bag



**2**  
Fold 60cm of line under the rescue.  
Secure the suspension line using the central elastic band



**3**  
Fold the paracord into symmetrical bundles the approximate width of the bag

Use elastic bands to hold the loops and neatly stack the bundles at the bottom of the bag



**4**  
Close the bottom flap in the order shown

There should be around 40cm of suspension line remaining to connect with the harness

## CONNECTING THE RESCUE BRIDLE

To connect a rescue to your harness we recommend using a GIN Rescue Carabiner. If you choose to use different type of connector, it should be rated at least 20 times the maximum weight. For example, our recommended 6mm Stainless Steel screwgate maillon (square) connector has a breaking load in excess of 28kN. It is the pilot's responsibility to check the compatibility of the rescue system and ensure that it is installed properly.

Be sure to inspect your connector during normal maintenance and safety checks. Replace it whenever there are any signs of wear and check your rescue system with a professional after any deployment. We recommend that you cover the connection using the Maillon rapid cover to prevent excess friction. Rubber-bands should also be used to secure the attachment and prevent excess friction.

**Recommended by GIN: 6mm stainless steel screwgate maillon**

**6MM SQUARE MAILLON**  
**BREAKING LOAD: >28KN**

### MAILLON CONNECTION *(RECOMMENDED BY GIN GLIDERS)*



## SHOULDER ATTACHMENT POINT

The Genie Race<sup>5</sup> comes with shoulder strap rescue bridles pre-installed. Please check before flight that both rescue bridles are correctly installed.

To access to rescue bridle connection, first open the top zipper and then the velcro tunnel.

Both velcro tunnel and rescue bridle zippered tunnel must be closed before take off.

**⚠ WARNING:** *When connecting the rescue bridle be sure to secure the connection using tape, rubber bands or heat shrink wrap. If the lines are not secure they may burn or cut from excess friction.*

**📌 IMPORTANT:** *Be sure to connect both rescue bridles to the rescue.*



1 Place the rescue in the container with the line loops facing DOWN



2 Pass the parachord through the fabric loops (White). Then, close the side flaps first



3 Close the main rescue flap



4 Pass the parachords through the fabric loop



5 Introduce the parachord tips through the fabric tunnel

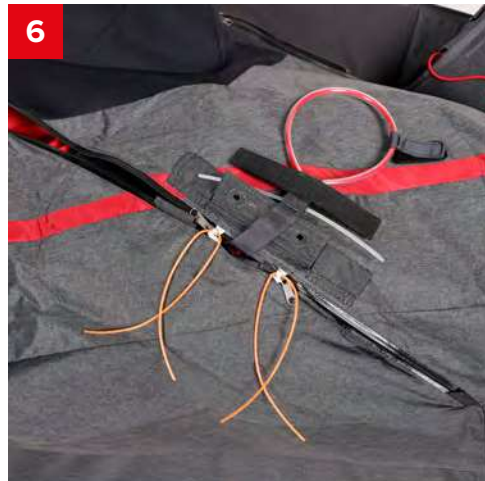

6 Pass the plastic parachord through the upper fabric loops

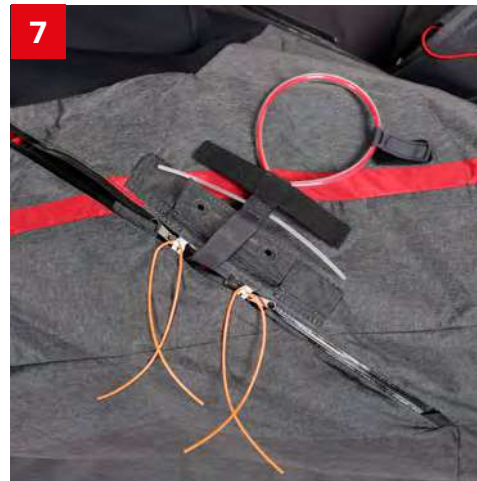

7 Pass the parachord into the bottom fabric loops

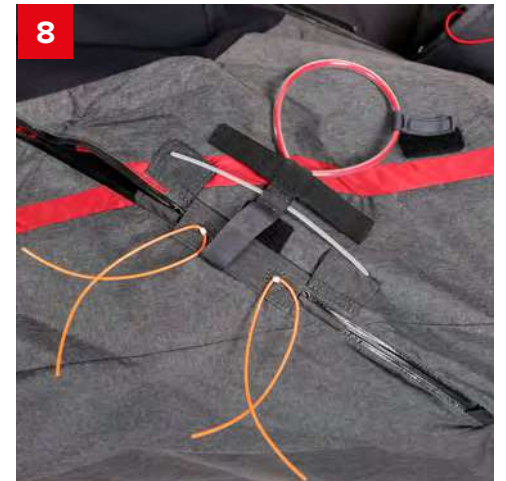

8 Pass the parachord through the fabric holes and pull



9 Pass the parachord through the fabric loop. Insert the remaining plastic parachord into the fabric tunnel and close the zipper until the end



10 Make sure the zipper puller has been introduced into the zipper tunnel pocket



11 Stick the velcro to the outershell velcro to maintain the handle position in flight



## FOOTPAD INSTALLATION GUIDE

The Genie Race 5 comes with 3 different sizes of footpads, 2,5cm, 5cm, 7,5cm. The footpad should be installed\* in the nose of the harness. The purpose of the footpad is to adjust the length of the outershell according to the length of the pilot legs. The footpad sets the tension on the outershell skin. If the outershell is too tight or too loose, the harness will develop wrinkles. Inflate the harness with an air source after installing the footpad to make sure the correct length was chosen.

\*Follow the installation instructions on the next page.

Guide for the size of footpad according to pilot height, the table data might differ depending on the leg length of the pilot

FOOTPAD SIZE	XS	S	M	L
PILOT HEIGHT	>165	160 - 175	170 - 180	>180
2.5 CM	160 - 165	170 - 175	180 - 185	190 - 195
5 CM	155 - 160	165 - 170	175 - 180	185 - 190
7.5 CM	150 - 155	160 - 165	170 - 175	180 - 185





1 Pass the white line with the metal buckle through the bar hole



2 Pass a plastic parachord through the white line loop



3 Introduce the parachord through the chosen footpad



4 Pass the white loop to the opposite side of the footpad (Velcro part).



5 Insert the bars into the crossed pockets



6 Insert the other side of the bars into the crossed pockets.

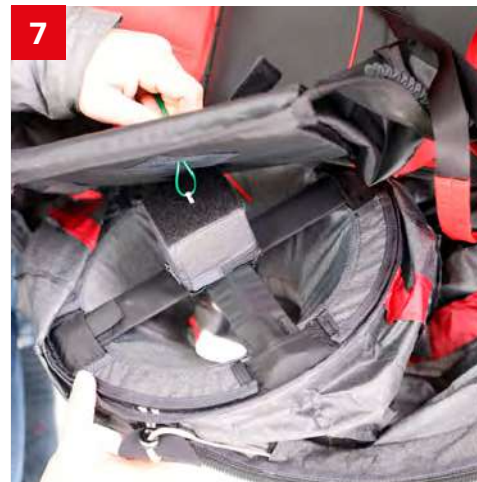

7 Pass the parachord through the harness foot plate



8 Introduce the metal pin through the white loop



Close the metal pin with the velcro layer



Close the large velcro flap



### **Too loose outershell, too short footpad**

If you install a footpad which is too short, the outershell will be loose and without tension



### **Too tight outershell, too long footpad**

If the footpad installed is too long, the outershell will show stress wrinkles because of the high tension



### **Correct tension**

Once you install the correct size of footpad, the inflated outershell should be wrinkle free with the correct balance of tension between the base structure and outershell

# STORAGE

## BACK POCKET (1)

The back pocket is designed to store the pilots rucksack and other light accessories during flight. with 30 L capacity and compression rope. To secure the proper inflation of the harness, the compression rope has to be pulled before flight

## UNDER SEAT POCKET (2)

The under seat pocket has a capacity of approx. 5L (M size) for ballast or other items. Bear in mind that any ballast placed here will affect the flying angle of the harness... you can use this to your advantage in fine tuning the harness; even 1kg will make a difference.

## HYDRATION POCKET / PERSONAL BELONGINGS (3)

The chest pocket is a smaller pocket that can hold a camera, snacks or other small belongings. The left chest pocket includes a channel routing for hydration, while the camel bag will be stored in the back pocket with a dedicated compartment.

## RADIO POCKET (4)

Located inside the chest pocket is a smaller pocket that can hold a camera, snacks or other small belongings. The right chest pocket includes a channel routing for a radio, while a hydration pack can be stored in the back pocket within a dedicated compartment. We recommend the use of a PTT mic for the radio.

## COCKPIT POCKET (5)

The cockpit storage pocket has a volume of 1L. It is designed to contain a powerbank, a pair of gloves or any other small items. It has a cable routing in order to be able to provide energy to your instruments during flight and is accessible in the air.

## BALLAST CONTAINER (6)

The ballast container has a capacity of 9L. It is not accessible in flight. It may also be used to store other items to be used after landing.

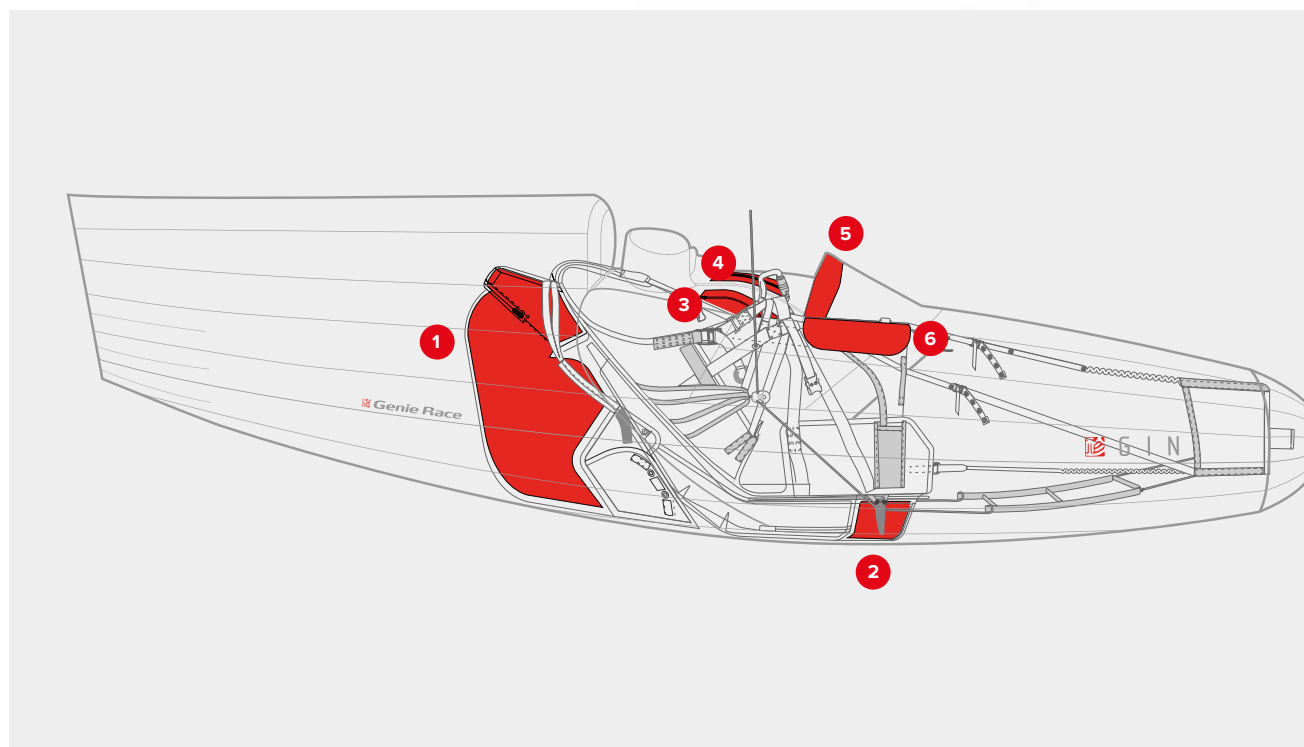

# ADJUSTMENTS

After choosing a harness that is close to your body size, adjust your harness to suit your physique and flying style. It is important to adjust it correctly to ensure you can easily slide into the sitting position after take off. A poorly adjusted harness can adversely affect the flying characteristics of your paraglider.

Perform adjustments before your first flight by hanging in a simulator and fine-tune the settings if necessary during your first few flights.

## SHOULDER STRAPS (1)

The optimum setting for the shoulder straps depends on the height of the pilot. Step into the harness and stand upright with the breast strap closed, symmetrically adjust the shoulder straps until they are a snug fit, but not tight.

To tighten: pull down on the red dotted loop

To loosen: pull up on the BLACK loop on the top of the shoulder strap.

## BREAST STRAP (2)

After adjusting the shoulder straps, place the breast strap in a comfortable position and tighten so there is slight pressure on the shoulder straps.

## LEG STRAPS

The leg strap lengths are not adjustable.

## ABS STRAPS (3)

The ABS system can't be adjusted on the Genie Race<sup>5</sup>

## LUMBAR STRAPS (3)

Bellow the breast straps you will find a buckle to adjust the lumbar strap. To get the back fully supported by all the seat, tighten the strap until the back pressure is distributed evenly.

**NOTE:** Make sure that the rescue system has been installed before making adjustments.

## VIDEO MANUAL

- You also can check the video manual for the harness settings of the Genie Race 5
- <https://www.youtube.com/watch?v=Rcmh4rn5UZk>



## LATERAL STRAPS (1)

The lateral straps adjust the angle between the thighs and the back. Lengthening the straps increases the angle and vice-versa. The easiest way to adjust them correctly is during a flight in calm air. Remember that flying in the supine position (i.e. leaning back), reduces the stability of the harness and increases the risk of riser twists after a deflation.

**TO TIGHTEN, PULL FORWARD ON BLACK AND RED LOOP. TO LOOSEN, PRESS THE BUTTON ON THE METAL TRIMMER.**

## SIDE STRAP (2)

The side adjustment straps allow you to adjust the angle of the lower back. To get the optimum setting you can loosen these straps to the maximum in the sitting position and start pulling the straps until you get the best comfort depending on the flying style of the pilot.

**TO TIGHTEN, PULL UP ON THE BLACK WEBBING. TO LOOSEN, PULL UP ON THE BUCKLE.**

## SPEED BAR

Hanging in the simulator, adjust the length of the speed bar cord so that the bar hangs at least 15cm below the front of the harness. Making the cord too short could result in the speed system being constantly or unintentionally engaged during flight. It is safer to start with the speed bar a little long and shorten it following your first flights. Test the speed bar in flight only after you are comfortable with your new harness, and always do so in calm conditions with enough clearance above the ground.

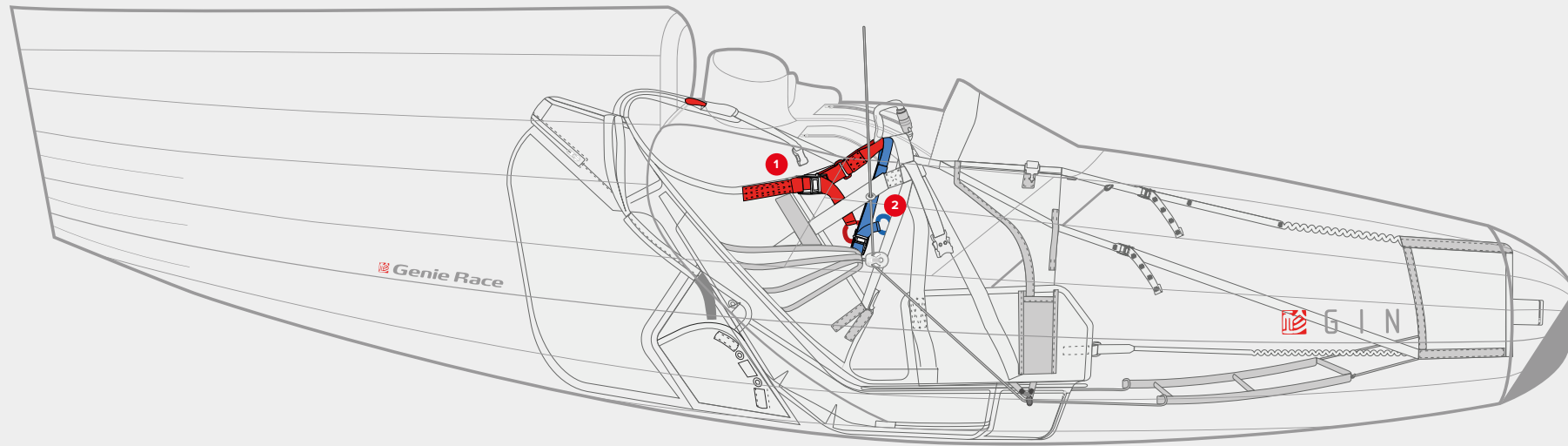

- 1 LATERAL STRAP**
- 2 SEAT STRAP**

## COCOON ADJUSTMENTS

The cocoon should be tight and the harness fabric should be smooth and wrinkle-free to create the most aerodynamic shape. The nose of the cocoon should form a straight line and point slightly down.

**(1)** Tighten the upper line to raise the nose of the cocoon, loosen to allow the nose to drop and extend the length of the cocoon. There are 7 markers on each adjustment line to help maintain symmetry.

**(2)** Tighten the lower line to adjust the overall length of the pod

There are 7 markers on each adjustment line to help maintain symmetry.

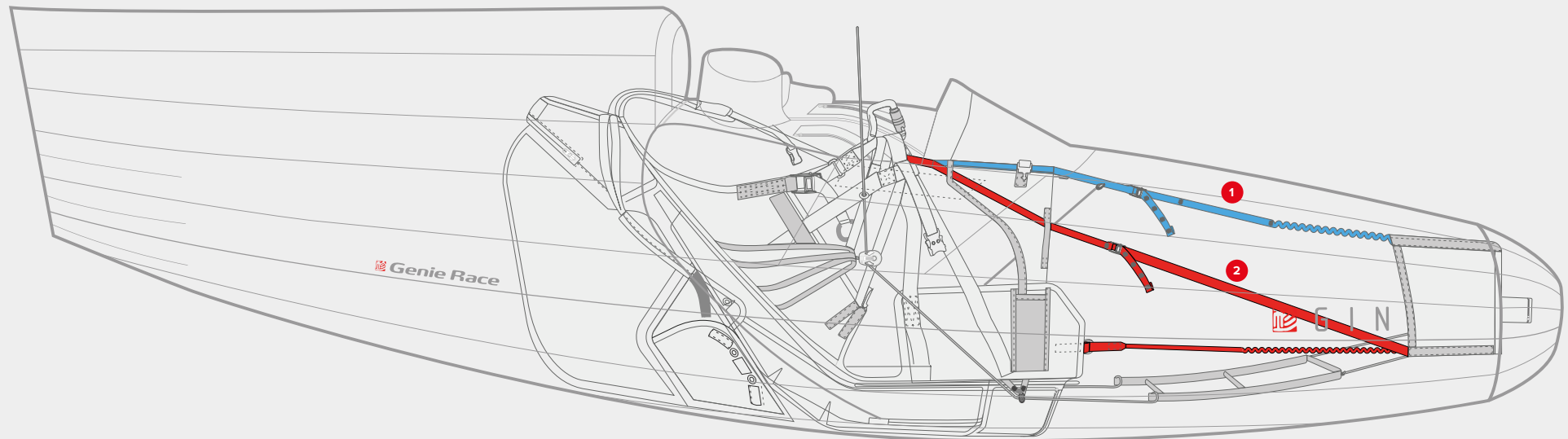

## COCOON ANGLE OF ATTACK

In order to get the maximum of performance out of your harness, the angle of attack should be 0°, compared to the horizon. Having the nose too high will not only affect performance, but also vision. Having the nose too low will have a detrimental effect on performance.

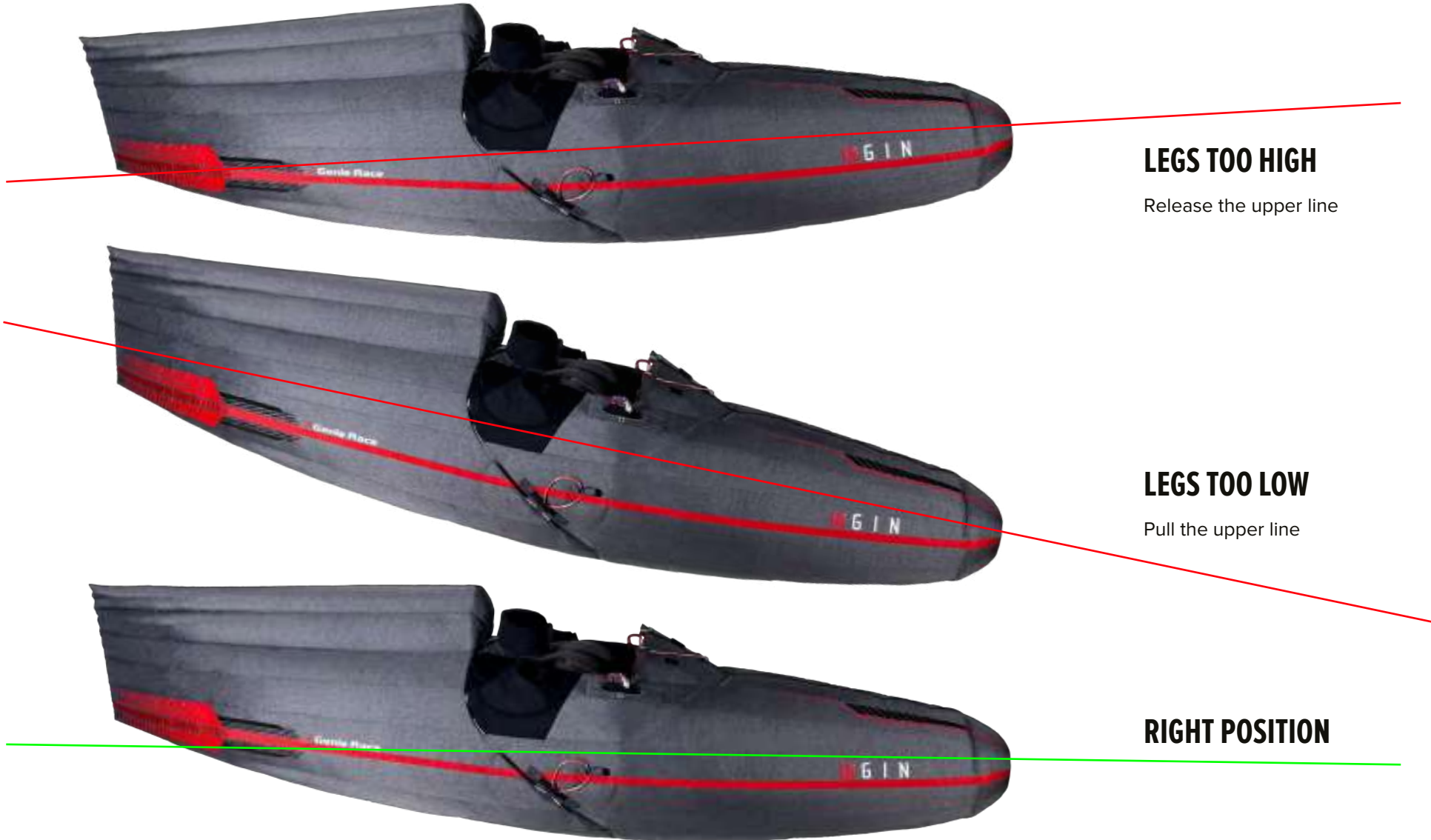

### LEGS TOO HIGH

Release the upper line

### LEGS TOO LOW

Pull the upper line

### RIGHT POSITION

## GUIDE TO PUTTING ON THE HARNESS

It is very important to put on the harness in the correct order and in the right way. Forgetting the leg straps or wearing the harness incorrectly may result in a fatal accident.

Please follow the following guide to learn how to put on the harness.

**⚠ WARNING:** Forgetting to connect the leg straps will place the pilot at risk of falling out of the harness, which may be fatal.



Introduce your arm inside the **shoulder strap** and take it out through the vest arm hole. Take care the shoulder strap is also being worn.



Introduce the other arm.



Close the first chest main aluminium buckle



Close the next buckle



### VIDEO MANUAL

- You also can check the video manual for the harness wearing guide of the Genie Race 5
- <https://www.youtube.com/watch?v=c6SuDh3RFPg>

## ATTACHING THE BALLAST CONTAINER (OPTIONAL)

Attach the ballast container only if needed. If you don't need to, please proceed to the instructions on the next page.



1 Attach the shoulder strap with the orange plastic buckle



2 Connect the front support pillar metal buckle and adjust the volume of the container with the red straps



3 Connect the front support pillar metal buckle and adjust the volume of the container with the red straps



4 Make sure the zipper is closed before closing the outershell of the harness

## CLOSING THE TOP ZIPPER

Attach the zipper slider and fully close the zipper until the end. If the zipper is not fully closed, the air pressure of the harness will be reduced. This will influence the external shape and may result in a loss of performance.



1 Attach the zipper slider at the bottom of the top zipper



2 Pull the slider until the top of the zipper (To the neck)

## CLOSING THE BOTTOM ZIPPER

Attach the zipper slider and fully close the zipper until the end. If the zipper is not fully closed, the air pressure of the harness will be reduced. This will influence the external shape and may result in a loss of performance.



1 Attach the zipper slider at the top of the bottom zipper



2 Pull the slider until the bottom end of the zipper

## ATTACHING THE FLIGHT DECK

Attaching the flight deck is obligatory in order to maintain the correct shape of the front section of the harness.



1 Connect the back velcro of the harness with the male velcro from the deck



2 Close the velcro flaps to secure the deck



3 Introduce the aluminium stick through the eyelet



4 Connect the other aluminium stick



1 Keep the flight deck in a high angle position before take off, the stick lines will pull the flight deck to the right flying position once airborne.



2 Flying position

## CLOSING THE COCOON ZIPPER (AFTER TAKE OFF)

The Genie Race 5 offers a dual zipper system. This system works through a system of lines which allows the pilot to pull the zipper for easy opening and closing from a seated position. The zipper can be opened in the air to refresh the air inside the harness before closing again.



Pull the red rope



Pull until the slider reaches the end of the track



The red line contains a magnet that has an attachment point at the top right of the cockpit area.

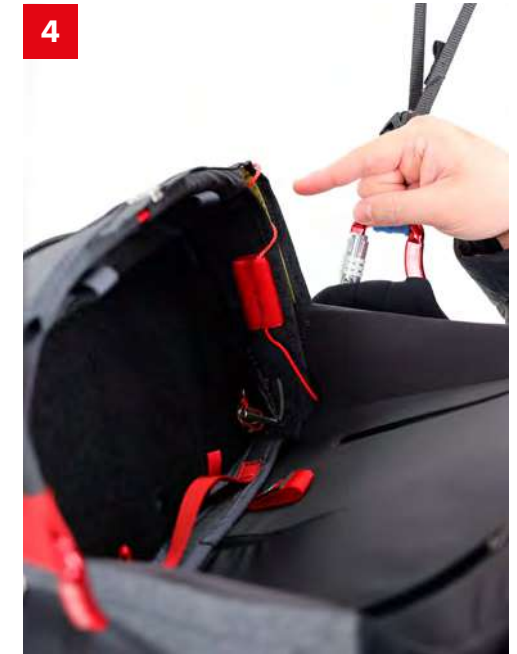

Store the extra line in the dedicated pocket and stick the velcro on the side of the flight deck

## OPENING THE COCOON ZIPPER (BEFORE LANDING)

The dual zipper system offers easy opening of the harness in any situation. We recommend opening the cocoon zipper with enough altitude and time before approaching the ground. Landing with the cocoon closed may result in an accident.

**1**

Pull the white line. The opening of the zipper will create tension on the red line, take care and check the red line is not stuck in the pocket of the harness.

**2**

Remove your legs from the cocoon on approaching the landing. We strongly recommend to open the cocoon with sufficient time to be ready for the landing. Landing with the legs inside the cocoon might create a dangerous situation.

# FLYING WITH THE GENIE RACE<sup>5</sup>

## General warnings and advice

Before every flight, check the following:

- ⦿ Are you in good physical and mental condition?
- ⦿ Are you familiar and compliant with all applicable laws and regulations in your area?
- ⦿ Are you within the certified weight range of your paraglider?
- ⦿ Do you have the necessary valid insurance cover (e.g. liability, medical, life)?
- ⦿ Are you briefed thoroughly about the site, airspace and expected weather conditions of the day?
- ⦿ Is your equipment and choice of site suitable for your level of experience?
- ⦿ Do you have a suitable helmet, gloves, boots, eye-wear and adequate clothing?
- ⦿ Are you carrying some form of identification, so that people know who you are in case of an accident?

Take along a radio and mobile phone if possible.

- ⦿ Do you fully understand how to safely use your new equipment? If not, have your instructor or dealer explain anything you are not sure about.

When you go for your first flight on your new harness, be sure to pick a day and site that does not present you with any unfamiliar challenges. During your first flight, familiarize yourself with the in-flight characteristics of your new harness.

## Pre-flight checks

As part of your normal pre-flight check routine, check:

- ⦿ Is there any damage to the harness or carabiners that could affect its airworthiness?
- ⦿ Is the rescue parachute container closed correctly with the pins in the right position?
- ⦿ Is the deployment handle correctly inserted or attached?
- ⦿ Are all buckles, belts, zips securely fastened? Buckles should click into place as you close them, and a gentle pull on the fastened buckle verifies this. Secure any zips after fastening the buckles. Take extra care in snowy or sandy environments.
- ⦿ Is the paraglider connected correctly to the harness with both carabiners secured by their locking mechanisms?
- ⦿ Is the speed bar attached correctly to the glider?
- ⦿ Are all pockets closed properly and any loose items tied down safely?
- ⦿ Is the air chamber intake open and clear?
- ⦿ Have you closed your leg and chest straps? Double check before you take off!



**i IMPORTANT:** Use a complete and consistent system of pre-flight checks and repeat the same sequence every flight.

**i IMPORTANT:** The maximum clip in weight of the Genie Race 5 is 120kg, we do not recommend you fly with more than this weight.

## Rescue Deployment

In the event of an emergency, you must quickly evaluate your height and the seriousness of the incident. A seconds hesitation in deploying the reserve could prove fatal if there is insufficient height. On the other hand, deploying the rescue when the glider is recoverable may result in needless injury.

If you decide to deploy the rescue:

- 1) Look for the rescue handle and grasp it firmly with one hand
- 2) Pull forwards and upwards on the handle to release the deployment bag from the rescue container.
- 3) Look for a clear area, and in a continuous motion, throw (and RELEASE!) The rescue away from yourself and the glider, preferably into the air stream or against the direction of spin. After deployment, avoid entanglement and pendulum motions by promptly pulling in the glider as symmetrically as possible with the B, C, D or brake lines.
- 4) On landing take an upright body position and be prepared to do a PLF (Parachute Landing Fall) to minimize the risk of injury.

## Landing with the Genie Race<sup>5</sup>

Before landing, you need to open the zipper by pulling the white line. Then slide your legs forward in the harness so that you adopt the standing position. NEVER land in the seated position—it is very dangerous even if you have back protection. Standing up before landing is an active safety precaution.



**i IMPORTANT:** *In normal flight, periodically feel the position of the rescue handle so that the action of reaching for the rescue handle is instinctive in an emergency.*

**! WARNING:** *During any incident in flight, always monitor your altitude. If you have any doubt that you have sufficient height for recovery, deploy your reserve without hesitation. “If in doubt, get it out!”.*

**NOTE:** *After any rescue deployment, it is essential to have your harness thoroughly inspected by a qualified professional to be sure there is no damage to the rescue connection points, rescue bridle or any other parts.*



### Towing

The Genie Race<sup>5</sup> can be used for towed launches. The Gin Towing Bridle can be hooked directly to the main carabiners. For further details, refer to the documentation provided with your tow release, or ask a qualified towing instructor at your flying site.



### Tandem Flying

The Genie Race<sup>5</sup> is not designed for tandem flying. See [www.gingliders.com](http://www.gingliders.com) for details of our harnesses specifically designed for tandem flying.



### Flying over water

Water landings should be avoided at all costs, as the back protection increases the risk of the pilot floating in a head-down position. For safety training over water, we recommend wearing a proper flotation vest with a head support holding the wearer's head above the surface even when unconscious. Don't land in the water with the cocoon zipper closed.

# MAINTENANCE AND REPAIRS

The materials used in this harness have been carefully selected for maximum durability. Nevertheless, keep your harness clean and airworthy to ensure the longest possible period of safe operation.

## Care and maintenance

Don't drag your harness over rough or rocky ground. Avoid unnecessary exposure to UV rays, heat and humidity. Keep the folded harness in your rucksack when not in use.

Store all your equipment in a cool, dry place, and never put it away while damp or wet. Regularly clean off dirt with a plastic bristled brush and/or a damp cloth. If the harness gets exceptionally dirty, wash it with water. Make sure you first remove the entire sub-components for example, rescue parachute etc. Allow the harness to dry naturally in a well ventilated area away from direct sunlight. If your rescue parachute ever gets wet (e.g. in a water landing) you must separate it from the harness, dry it and repack it before putting it back in its separate deployment bag.

After a hard landing you must check your harness and back protector for damage, pay close attention to the rescue container and verify all of the attachments are secure.

If minor damage occurs, you can order specific sticky fabric for the outershell of the Genie Race 5. Please get in touch with your local dealer to order.

If major damage occurs to your outershell, it can be ordered separately and easily fitted to your base structure. Please get in touch with your local dealer to order.

## Inspection checklist

The pilot should perform the following inspection on every repack of the rescue and should be checked by a professional after 24 months or 200 hours of flying, whichever comes first. Additional inspections should be performed after any crash, bad landing or take off, or if there are any signs of damage or undue wear. Always seek professional advice whenever in doubt.

**! IMPORTANT:** *Any repairs should only be carried out by the manufacturer or by an approved agent. This will ensure that the correct materials and repair techniques are used.*

**! IMPORTANT:** *No harness should ever be flown if there is any kind of damage to the webbing.*

### The following checks should be carried out:

- ⊙ Check all webbing, straps and buckles for wear and damage (ex. open seams, tearing or cutting), especially the areas that are not easily seen, such as the inside of the carabiner hook-in points.
- ⊙ All sewing must be intact and any anomalies attended to immediately to avoid exacerbation of the problem.
- ⊙ Special attention should be paid to the rescue installation, particularly the elastic and Velcro parts.
- ⊙ The main carabiners must be replaced at least every 5 years or after 500 hours, whatever comes first. Impacts may create undetectable cracks that could result in structural failure under continuous load.
- ⊙ A careful visual inspection of the protector should be made, airbags should be filled with air and checked for leaks, mousbag should be inspected for tears and foam recovery.

### Repairs

The manufacturer or an official GIN dealer should carry out any repair that involves critical parts of the harness. This will ensure that the correct materials and repair techniques are used. A sticky repair fabric is available that you can order to fix small tears to the outershell

### Storage

Store at a temperature between 10° and 25° C and in relative humidity between 50 and 75%. Make sure that the harness is not stored in a place where animals such as mice or cats could use it as a place to sleep.

Do not store the harness near any chemicals (including water). Petrol, for example, causes the material to disintegrate and can cause considerable damage to your harness. When your equipment is in the car boot, keep it as far away as possible from any spare petrol cans or oil containers.

The harness should not be exposed to extreme heat. High temperatures accelerate the process of hydrolysis, particularly when combined with moisture, which damages fibers and coating. Do not store your harness near radiators or other heat sources.

*If you find your Aerocone not inflating well, consider putting fewer items in the back pocket, as the air intake might be blocked*



## GIN quality and service

We take pride in the quality of our products and are committed to putting right any problems affecting the safety or function of your equipment and which are attributable to manufacturing faults. Your GIN dealer is your first point of contact if you have any problems with your equipment.

If you are unable to contact your dealer or GIN importer, contact Gin Gliders directly via our website.

## GIN lifetime guarantee

Gin Gliders are proud to guarantee the quality, craftsmanship and performance of all our products. Equipment with defects in materials or manufacturing will be repaired or replaced at the discretion of Gin Gliders for the practical lifetime of the product. Equipment damaged through wear and tear, misuse or neglect may be repaired at a nominal charge.

If you have any problems with your equipment, please contact your GIN dealer in the first instance, or Gin Gliders directly via our website.

## Care of the environment

We are privileged to fly in areas of outstanding natural beauty. Respect and preserve nature by minimizing your impact on the environment. When visiting an area, contact the local club for details of environmentally sensitive areas and local restrictions.

Gin Gliders gives consideration to the entire life cycle of its harnesses, the last stage of which is recycling in an environmentally-friendly manner. The synthetic materials used in a harness must be disposed of properly. If you are not able to arrange appropriate disposal, Gin Gliders will be happy to recycle the harness for you. Send the harness with a short note to this effect to Gin Gliders Inc.

## Product registration

Register this product to receive any important safety updates.

[www.gingliders.com/register](http://www.gingliders.com/register)



## FINAL WORDS...

Most of us today live in a dependent society where we are regulated and protected. There are few opportunities for individuals to develop the self-responsibility that is the foundation of safety in extreme sports such as paragliding.

Most accidents are caused by getting into situations that are too demanding for your level of experience. This happens if you lack fundamental understanding, are incapable of assessing the risk or simply do not pay sufficient attention to your surroundings or your own state of mind.

To stay safe, the best you can do is to increase your understanding, skill and experience at a rate you can manage safely. There is no substitute for self-responsibility and good judgment.

In the end, paragliding offers a unique opportunity to learn to take control of your own destiny. Memento mori, carpe diem!



G I N

Fly safely, and...**ENJOY!**

GIN team

# TECHNICAL DATA

Size	XS	S	M	L	XL
Carabiner distance (cm)	44	45	45	47	47

## CERTIFICATION

The Genie Race<sup>5</sup> is **EN** and **LTF** certified, max load 120 daN  
 Certification number: **PH 387.2023** | **CE** certification

## PARACHUTE CONTAINER

Integrated double container underneath the  
 back support

## BACK PROTECTION

KOROYD 9cm Back Protection

# MATERIALS

Harness fabric	
Outer	?
Inner	Nylon HD 210
Webbing	Nylon HD 210Nylon 20mm
	Polyester 30mm/25mm/20mm
Thread	100% Polyester, P/F 210D/9 bonded, P/F 210D/4 bonded & P/F 210D/6 bonded

# PILOT DETAILS / PROOF OF OWNERSHIP

## 1. Owner

Name:

Address:

Phone:

Email:

## 2. Owner

Name:

Address:

Phone:

Email:

## 3. Owner

Name:

Address:

Phone:

Email:

# HARNESSES DETAILS

Size	Colour	Serial Number
Check flight (date):		
Mark and signature:		

# INSPECTIONS AND REPAIRS OVERVIEW

Date	Work carried out	General conditions on delivery	Completed by (name)	Stamp and signature

# HARNESSE DIAGRAM



# HARNESSESS DIAGRAM

- 1** Back pocket  
*30L capacity*
- 2** 2 Rescue containers  
*9800 cm<sup>3</sup> volume (M size)*
- 3** 2 Rescue handle and innerbag
- 4** Underseat pocket  
*3L capacity, suitable for ballast*
- 5** Support pilars
- 6** Ballast container  
*9L capacity*
- 7** Large external cockpit  
*Easy access during flight*
- 8** 2 Chest pockets  
*For food or small items*
- 9** H2O + radio mic routing  
*Chanel to back pocket*
- 10** 30mm Gin aluminium carabiner
- 11** Adjustable shoulder straps  
*Adjustable in flight*
- 12** Lateral straps  
*Adjustable in flight*
- 13** Leg length trimmer
- 14** Cocoon angle trimmer
- 15** 3 Step asymmetric speedbar  
*Included*
- 16** Front air inlet
- 17** Foot plate with foot pad  
*3 different lengths: 2.5cm / 5cm / 7.5cm*
- 18** Allen-A2030Tii Pulley  
*(Single Til-On 8mm)*
- 19** Dual opening zipper system  
*Easy opening and closing system*
- 20** Outlet for catheter system  
*(pee tube)*
- 21** Cobra buckles  
*Get up system*
- 22** 9cm full Koroyd protector





**Gin Gliders**

2318-32, Baegok-daero,  
Mohyeon-myeon, Cheoin-Gu,  
Yongin-city, Gyeonggi-Do,  
17036 Korea

[www.gingliders.com](http://www.gingliders.com)